



VA(M)S-70 Series — Installation Instructions

06/30/22

Applications:

The VA(M)S-70 Series Electric Spring Return Actuators are direct-mount valve actuators that operate on AC/DC 24 V power. These bidirectional actuators are used to provide accurate positioning on Bray's ST2 Series 1-1/4, 1-1/2, and 2 in. (DN32, DN40, and DN50) ball valves in Heating, Ventilating, and Air Conditioning (HVAC) applications. Integral line voltage auxiliary switches, available only on the (-A) models, indicate end-stop position, or perform switching functions within the selected rotation range.

IMPORTANT:

Use this VA(M)S-70 Series Electric Spring Return Actuator only to control equipment under normal operating conditions. Where failure or malfunction of the electric actuator could lead to personal injury or property damage to the controlled equipment or other property, additional precautions must be designed into the control system. Incorporate and maintain other devices, such as supervisory or alarm systems or safety or limit controls, intended to warn of or protect against failure or malfunction of the electric actuator.

Installation:

Install the ball valve with the actuator at or above the center line of the horizontal piping (see Figure 1).

IMPORTANT:

In steam applications, install the valve with the stem horizontal to the piping. Failure to follow this precaution may shorten the life of the actuator.

IMPORTANT:

Before specifying VA(M)S-70 Series Electric Spring Return Valve Actuators for plenum applications, verify acceptance of exposed plastic materials in plenum areas with the local building authority. Building codes for plenum requirements vary by location. Some local building authorities accept compliance to UL 1995, Heating and Cooling Equipment, while others use different acceptance criteria.

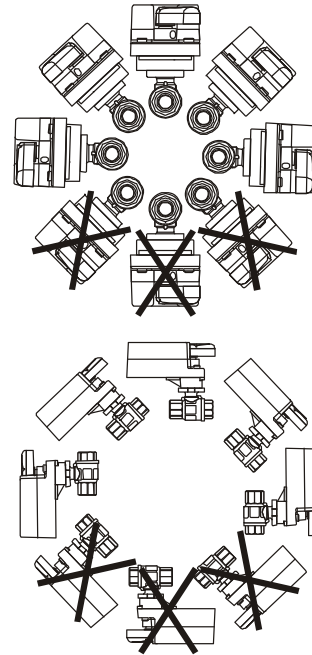

Figure 1: Mounting Positions for Chilled Water and Condensing Atmosphere Applications

IMPORTANT:

Do not install or use this VA(M)S-70 Series Electric Spring Return Valve Actuator in or near environments where corrosive substances or vapors could be present. Exposure of the actuator to corrosive environments may damage the device's internal components, and will void the warranty.

Special Tools Needed

- Commissioning Tool or digital voltmeter
- T-20 TORX® driver



VA(M)S-70 Series — Installation Instructions - Continued

Dimensions:

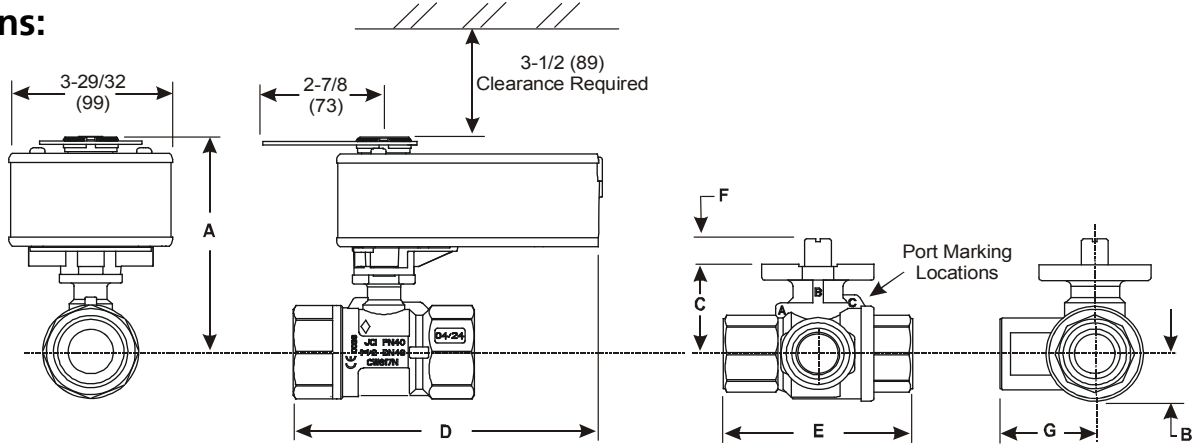

Figure 2: Spring Return VA(M)S-70 Series Ball Valves - Dimensions, in. (mm)

VA(M)S-70 Series Ball Valve Ball Valve Dimensions, in. (mm)

Valve Size in. (DN)	Valve Style ¹	A	B	C	D	E	F	G
1-1/4 (DN32)	All	5-5/32 (131)	1-1/32 (26)	1-23/32 (44)	7-1/4 (184)	3-15/16 (100)	11/32 (9)	1-31/32 (50)
1-1/2 (DN40)	All	5-5/16 (135)	1-9/64 (29)	1-57/64 (48)	7-7/16 (189)	4-21/64 (110)	11/32 (9)	2-11/64 (55)
2 (DN50)	2-Way	5-17/32 (140)	1-15/32 (37)	2-1/8 (54)	7-11/16 (195)	4-27/320 (132)	11/32 (9)	2-27/64 (62)
	3-Way				7-7/8 (200)			2-27/64 (62)

1. Port A must always be connected the coil (Figure 2).

Dimensions:

(With Thermal Barrier Installed)

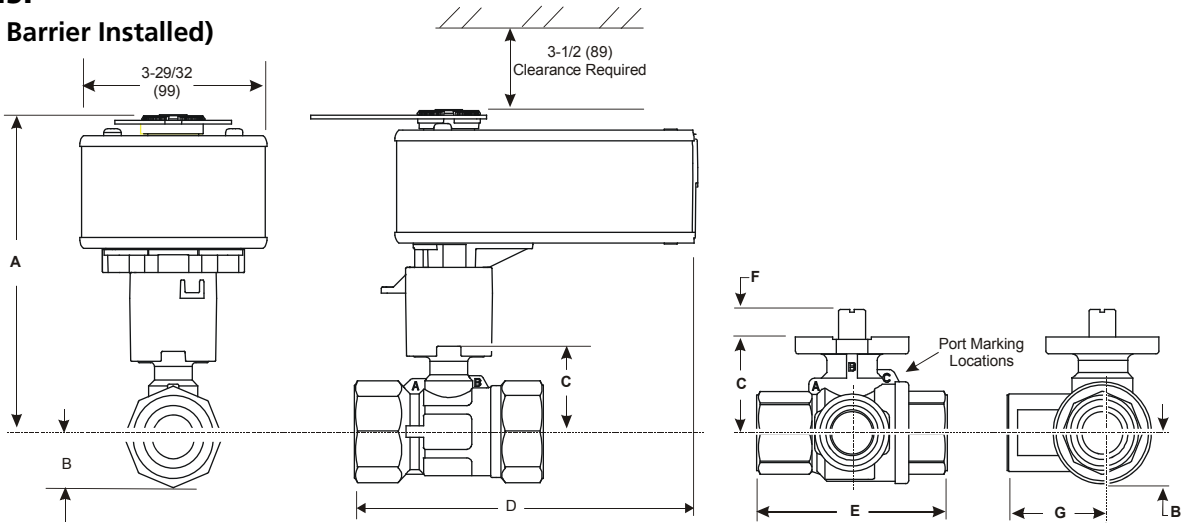

Figure 3: Spring Return VA(M)S-70 Series Ball Valves (With Optional Thermal Barrier) - Dimensions, in. (mm)

VA(M)S-70 Series Ball Valve Ball Valve Dimensions - (With Optional Thermal Barrier Installed), in. (mm)

Valve Size in. (DN)	Valve Style ¹	A	B	C	D	E	F	G
1-1/4 (DN32)	All	9-17/64 (235)	1-1/32 (26)	1-23/32 (44)	7-1/4 (184)	3-15/16 (100)	11/32 (9)	1-31/32 (50)
1-1/2 (DN40)	All	9-15/16 (240)	1-9/64 (29)	1-57/64 (48)	7-7/16 (189)	4-21/64 (110)	11/32 (9)	2-11/64 (55)
2 (DN50)	2-Way	9-31/32 (244)	1-15/32 (37)	2-1/8 (54)	7-11/16 (195)	4-27/32 (123)	11/32 (9)	N/A
	3-Way				7-7/8 (200)			2-27/64 (62)

1. Port A must always be connected the coil (Figure 3).



Mounting

Mounting the Actuator to Spring Return Port A (Coil) Open

To mount the actuator to Spring Return Port A (Coil) open:

1. Turn the valve stem to the position outlined in Figure 4.

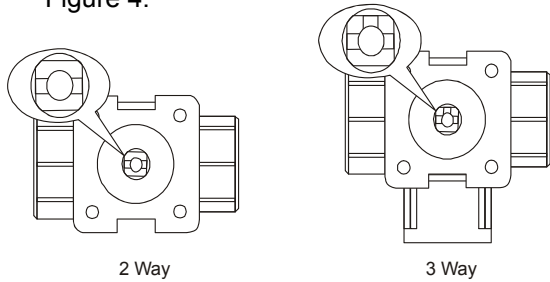

Figure 4: Positioning the Valve Stem

2. Mount optional Thermal Barrier to the valve if fluid temperature exceeds 212°F (100°C). See the [Mounting the Thermal Barrier](#) section for more information.

Note: Proceed to Step 7 if the ball valve linkage is on actuator Side B.

3. Remove the linkage from Side A (Figure 5).

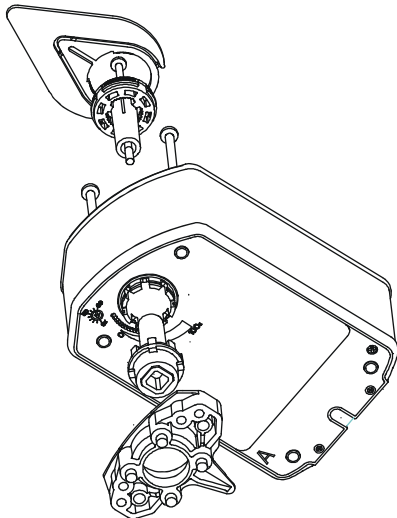

Figure 5: Removing the Linkage

4. Insert the drive shaft into Side B (Figure 6).

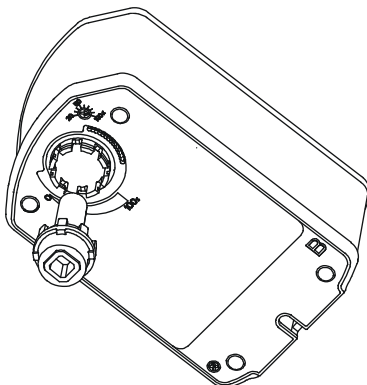

Figure 6: Inserting the Drive Shaft

5. Install linkage base on Side B using the two #10-14 x 2.75 in. long screws (Figure 7). The recommended torque is 20 to 24 lb·in. (2.3 to 2.7 N·m).

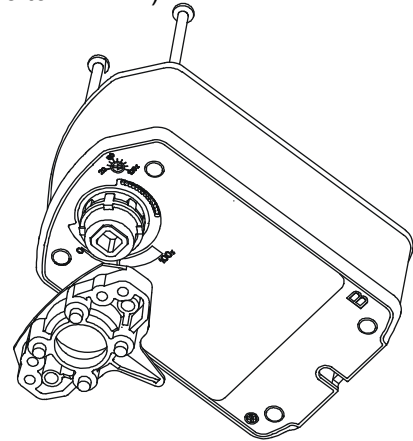

Figure 7: Installing the Linkage

6. Insert fixed pointer and M4x0.7x83 mm long screw into the Side A actuator hub. Direct the arrow on the pointer to 100%.

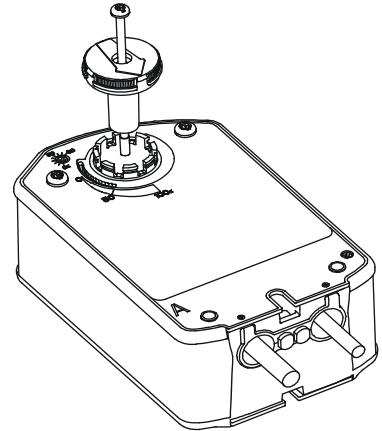

Figure 8: Installing the Fixed Pointer

7. Install the actuator on the ball valve (Figure 9). Tighten the actuator mounting screw to a torque of 10 to 12 lb·in. (1.1 to 1.4 N·m) and snap in the large adjustable pointer into place.

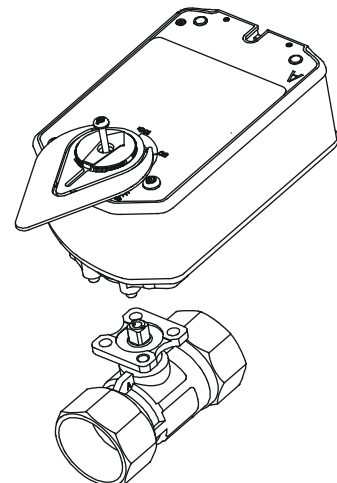

Figure 9: Mount the Actuator



Mounting the Actuator to Spring Return Port A (Coil) Closed

To mount the actuator to spring return port A (coil) closed:

1. Turn the valve stem to the position outlined in Figure 10.

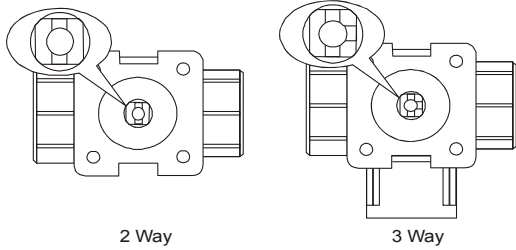

Figure 10: Positioning the Valve Stem

2. Mount optional Thermal Barrier to the valve if fluid temperature exceeds 212°F (100°C). See the [Mounting the Thermal Barrier](#) section for more information.

Note: Proceed to Step 7 if the ball valve linkage is on actuator Side A.

3. Remove the linkage from Side B (Figure 11).

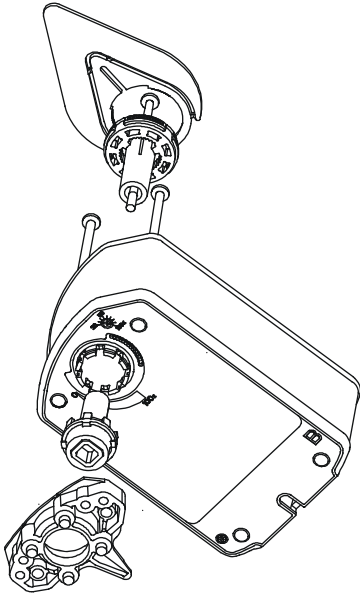

Figure 11: Removing the Linkage

4. Insert the drive shaft into Side A (Figure 12).

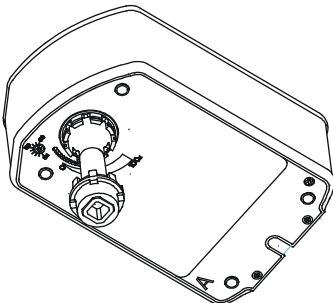

Figure 12: Inserting the Drive Shaft

5. Install linkage base on Side A using the two #10 14 x 2.75 in. long screws. The recommended torque is 20 to 24 lb·in. (2.3 to 2.7 N·m).

6. Insert fixed pointer and M4x0.7x83 mm long screw into the Side B actuator hub. Direct the arrow on the pointer to 0% (Figure 14).

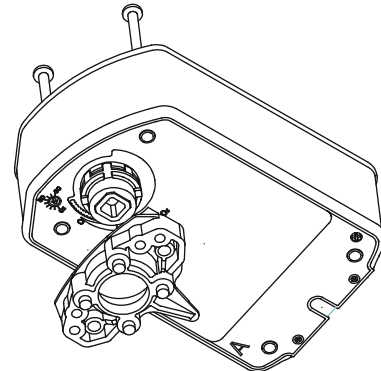

Figure 13: Installing the Linkage

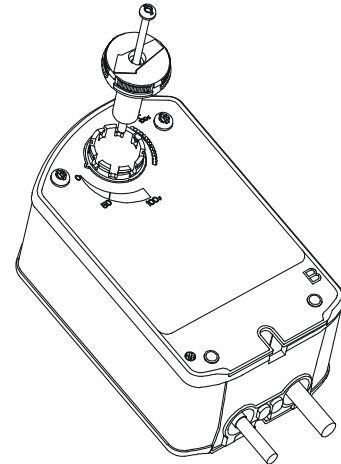

Figure 14: Installing the Fixed Pointer

7. Install the actuator on the ball valve (Figure 15). Tighten the actuator mounting screw to a torque of 10 to 12 lb·in. (1.1 to 1.4 N·m) and snap the large adjustable pointer into place.

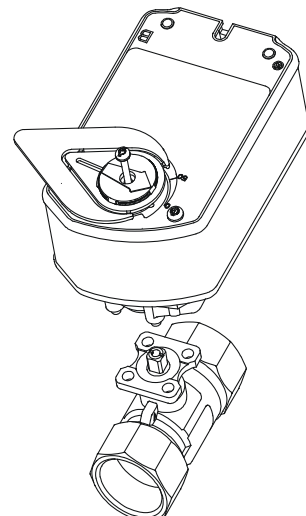

Figure 15: Mount the Actuator



Mounting the Thermal Barrier

Figure 16 shows the optional Thermal Barrier.

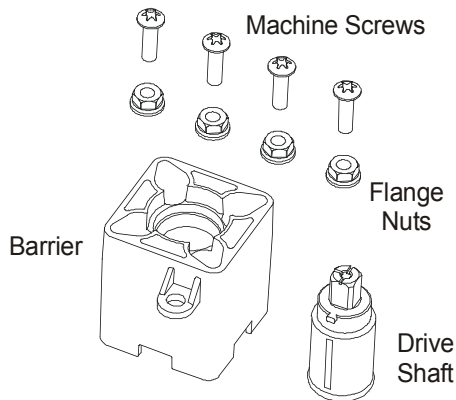

Figure 16: Optional Thermal Barrier

To mount the optional thermal barrier:

1. Install the thermal barrier drive shaft into the thermal barrier by aligning the tab on the drive shaft with the slot on the thermal barrier (Figure 17).

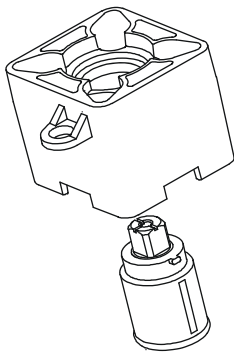

Figure 17: Installing the Drive Shaft into the Thermal Barrier

2. Rotate the drive shaft to align marks on the top of the thermal drive shaft with matching marks on the valve stem.
3. Mount the thermal barrier onto the valve using the four included M5x16 mm machine screws and four M5 flange nuts. Tighten the screws to a recommended torque of 21 to 25 lb-in. (2.4 to 2.8 N·m) (Figure 18)

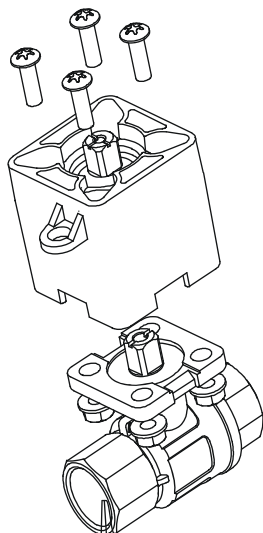

Figure 18: Installing the Barrier

4. Proceed to the actuator mounting instructions. Follow the same steps as mounting directly to the valve when mounting actuator to the thermal barrier.

Note: Depending on your application, you may position the assembly in any of the four 90° increments on the valve.

Manual Override

Use only the supplied manual override crank to reposition the actuator hub when using the manual override feature.

IMPORTANT: Applying excessive torque to the manual override or operating the manual override with a power tool may damage the internal components of the actuator and cause premature failure.

To reposition the actuator hub, proceed as follows:

1. De-energize the actuator.
2. Insert the hex end of the manual override crank into the manual override adjustment point on the face of the actuator.
3. Rotate the manual override crank in the direction indicated by the arrow on the label.
4. The actuator requires 8-1/2 manual override crank rotations from the full spring return position to fully reposition the actuator hub. At the end of travel, the rotation resistance increases. Do not force the manual crank past this point.
5. While holding the manual crank in the wound position, rotate and hold the red lock shaft approximately 10° then release the manual crank to lock the actuator hub in place.

Note: Insert and slightly rotate the manual crank in the direction indicated by the arrow on the label to unlock the actuator hub. Alternately, the actuator hub automatically unlocks when power is applied to the actuator, and returns the actuator to normal drive and spring return operation.



VA(M)S-70 Series — Installation Instructions - Continued

Wiring

VAS24-70-(A)

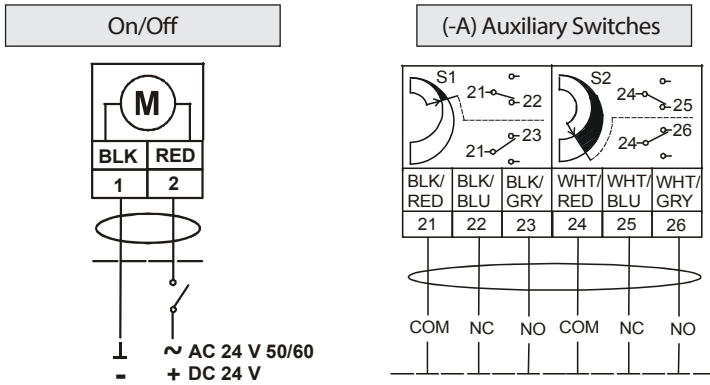

VAS120-70-(A)

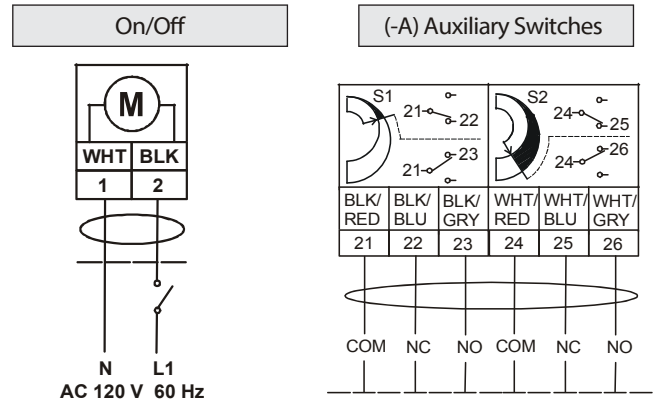

VAMS24-70-(A)

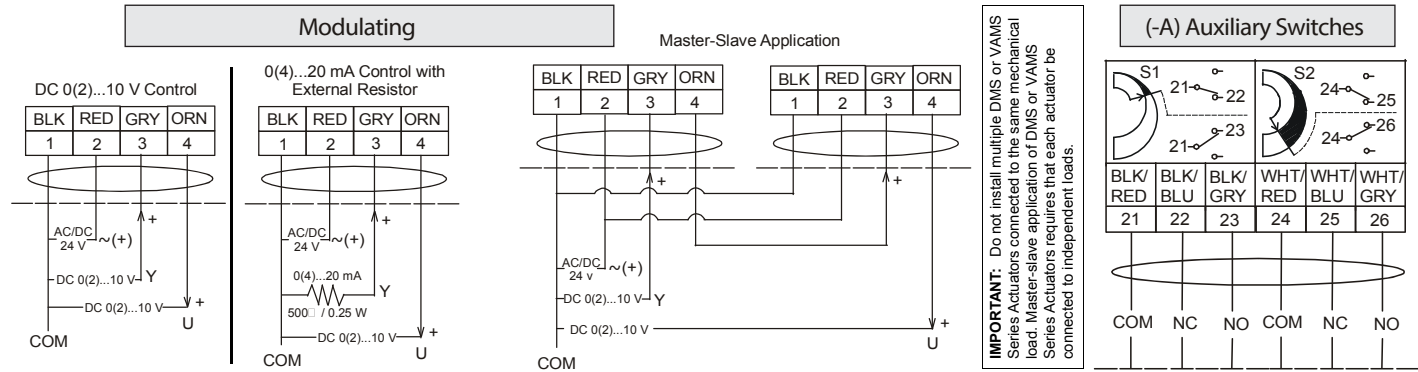

VAS24-70-T(A)

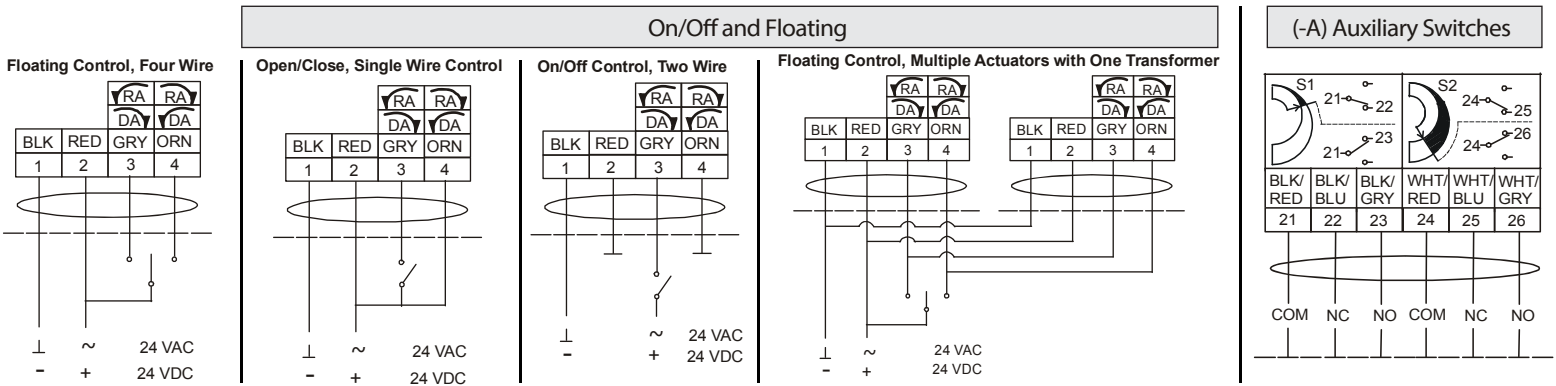

WARNING: Risk of Electric Shock. Disconnect or isolate all power supplies before making electrical connections. More than one disconnect or isolation may be required to completely de-energize equipment. Contact with components carrying hazardous voltage can cause electric shock and may result in severe personal injury or death.

CAUTION: Risk of Property Damage. Do not apply power to the system before checking all wiring connections. Short circuited or improperly connected wires may result in permanent damage to the equipment.

CAUTION: Risk of Property Damage. Insulate and secure each unused wire lead before applying power to the actuator. Failure to insulate and secure each unused wire lead may result in property damage.

IMPORTANT: Make all wiring connections in accordance with the National Electrical Code and local regulations. Use proper Electrostatic Discharge (ESD) precautions during installation and servicing to avoid damaging the actuator's electronic circuits.

NOTE: WARNING: All VA(M)S-70 Series actuators are designed for use only in conjunction with operating controls. Where an operating control failure would result in personal injury and/or loss of property, it is the responsibility of the installer to add safety devices or alarm systems that protect against, and/or warn of, control failure.

The performance specifications are nominal and conform to acceptable industry standards. For application at conditions beyond these specifications, consult the nearest Bray office. Bray controls shall not be liable for damages resulting from misapplication or misuse of its products.



Using Conduit

All VA(M)S-70 Series Actuators accept 3/8 in. (10 mm) trade size flexible metal conduit.

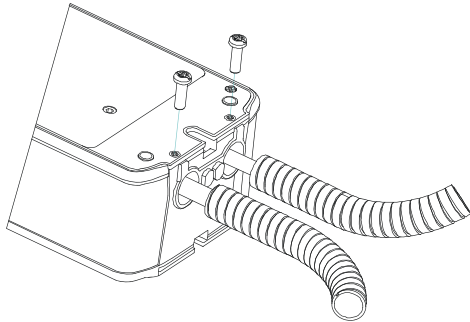

Figure 21: Adding Flexible Metal Conduit

1. Feed the actuator cables through the field-supplied conduit.
2. Push the conduit into the holes in the actuator and secure it with the supplied 10-32 x 9/16 in. screws, as illustrated in Figure 21. The product label marks the position of holes for the screws. Drive the screws through the product label in the marked positions. Drive the screwhead flush with the plate to secure the conduit.

IMPORTANT: Careful workmanship is required to secure flexible metal conduit. Cut the conduit end perpendicular to its axis. Insert the cut end into the bottom of the holes in the actuator and hold the conduit in place while securing it with the screws provided. Check a completed installation by pulling on the conduit to ensure its retention.

Mode Selection Switch

Actuators have an external mode selection switch to reverse control logic. The switch is accessible from both A and B sides of the actuator as illustrated in Figure 22. Actuators are delivered in Direct Acting (DA) mode and can be switched by the user to Reverse Acting (RA) mode.

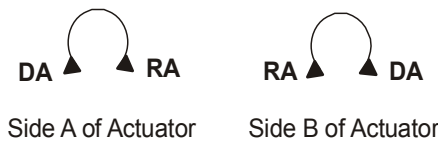

Figure 22: Mode Selection

Control Response

The installation side of the actuator and the position of the mode selection switch combine to determine control response from the actuator. See Figure 23.

		Installation Side			
		A		B	
Control Inputs		Mode Selection Switch			
GRY	ORN	DA/RA		RA/DA	
3	4	DA	RA	RA	DA
CLOSED	OPEN	↘	↙	↘	↙
OPEN	CLOSED	↙	↘	↙	↘
OPEN	OPEN	STOP	STOP	STOP	STOP
CLOSED	CLOSED	↘	↙	↘	↙

Figure 23: Control Response

Auxiliary Switch (-A Models)

The -A models include two integral auxiliary switches with a switch adjuster accessible on either face of the actuator (Figure 5). The factory setting for Auxiliary Switch No. 1 is 83% closing, and the nominal setting for Auxiliary Switch No. 2 is 10% opening (relative to the 0 to 100% rotation range as printed on the product label). See the Technical Specifications table for the auxiliary switch ratings.

The switch point of Auxiliary Switch No. 1 is fixed. The switch point of Auxiliary Switch No. 2 is independently and continuously adjustable from 74 to 5% position. For the most accurate switch positioning, see Figure 24 and use the method in the following example. To change the switch point of Auxiliary Switch No. 2, proceed as follows:

1. Position the actuator in the full spring return position.

Note: The switch is factory set to trip when the actuator reaches the 10% position.

2. Rotate the switch adjuster until it points to the desired switch point.

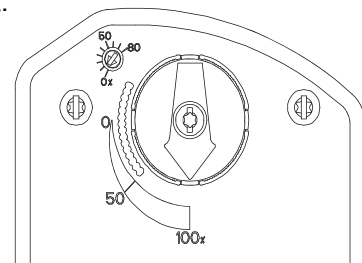

Figure 24: Switch Trip Point Settings

3. Connect Auxiliary Switch No. 2 to a power source or an ohmmeter and apply power to the actuator. The actuator moves to the fully open position and holds while power is applied.
4. Observe the switch point. If required, repeat Step 1 through Step 3.